

0. INSTRUCTION AND OPERATION MANUAL

CONTENTS

1. DESCRIPTION	1
2. HANDLING	1
3. INSTALLATION	2
4. PNEUMATIC CYLINDER.....	4
5. MAINTENANCE.....	4
5.1. Replacement packing kit.....	5
5.2. Replacement of the seal (only for tight valves).....	7
5.3. Replacement of the cylinder	8
5.4. Replacement of accessories.....	9
5.5. Greasing.....	9
6. STORAGE	10
7. ENVIRONMENTAL CONSIDERATIONS.....	10

THIS INSTRUCTIONS MANUAL COMES WITH A GENERAL PLAN WHICH INCLUDES A LIST OF MATERIALS OF THE VALVE SUPPLIED.



1. DESCRIPTION

The MP model is a general-purpose, uni-directional flanged valve for gaseous clean fluids such as atmospheric air, nitrogen, oxygen etc. and gaseous dirty fluids carrying suspended solids. For the latter application the valve has a register for both the build-up of solids and cleaning.

This is a valve which, due to its mechanical system of movement, offers several advantages compared to other butterfly valves. These advantages include the elimination of friction between the disc and the seat thus lengthening the valve's service life.

This model is mainly divided into 2 types; low pressure with values equivalent to 6 bar and high pressure, with pressures up to 40 bar. Likewise, as far as tightness is concerned, these valves are mainly constructed in 2 versions. The first of these with graphite-based braiding providing BO class 3 tightness according to standard DIN 3230 and the second providing relative tightness with metal-metal contact.

2. HANDLING



Pay special attention to the following points when handling an Orbinox valve:

- **Use the lifting lugs** which all valves of this type have for moving and handling purposes:

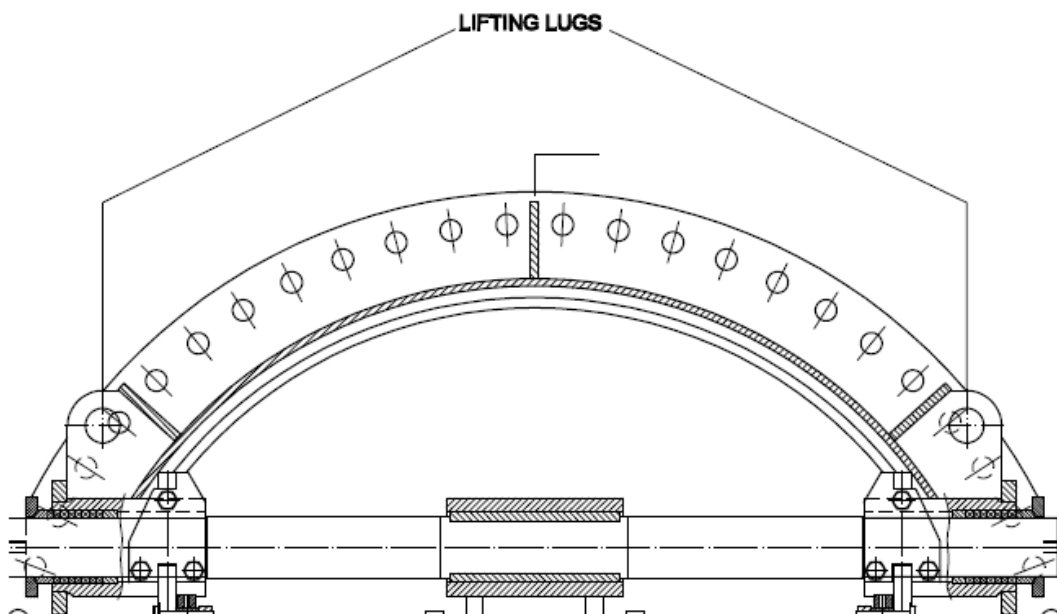

- **Do not lift the valve by holding it by the stem or the actuator support plate.** The valve would go totally off balance, possibly be damaged and injure the personnel handling it.

- **Do not lift the valve by holding it by the bore or port.** This can cause damage to the surface of the seat, seals and the flange raised face.

SAFETY WARNING:

- Ensure that the crane, as well as the belts or slings used, are correctly set for lifting the weight of the valve.
- These valves have support legs to prevent them from rolling while being tested or handled. These legs cannot be used to support the valve weight when being installed, nor can they be used for supporting the weight of the pipes.

3. INSTALLATION



It is important to observe the following warnings to avoid personal injuries or damage to property when handling and installing the valve:

- It is the User's responsibility to verify compatibility of valve parts materials with the internal fluid.
- Qualified and trained personnel must carry out the handling and maintenance of the valve.
- Use suitable Individual Protection Equipment (IPE) (gloves, safety footwear...).
- Disconnect all lines affecting the valve and put up a notice notifying that work is being carried out on the valve.
- Isolate the valve Completely from the process.
- Release process pressure.
- Drain the fluid from the valve.

Before installing the valve, inspect it to check that it has not suffered any damage during transit or storage.

Ensure that the body inside is clean, taking special care with the seat area. Also ensure that the neighbouring areas where the valve is to be installed are clean (flanges, pipes...).

As a uni-directional valve, it has to be installed in such a way that the PRESSURE pushes the disc towards the SEAT. These valves have an arrow riveted in the valve body indicating the direction of pressure. It is the user's responsibility to correctly install and direct the valve in relation to the direction of pressure.



It is useful to remember that the direction of flow does not necessarily coincide with the direction of pressure.

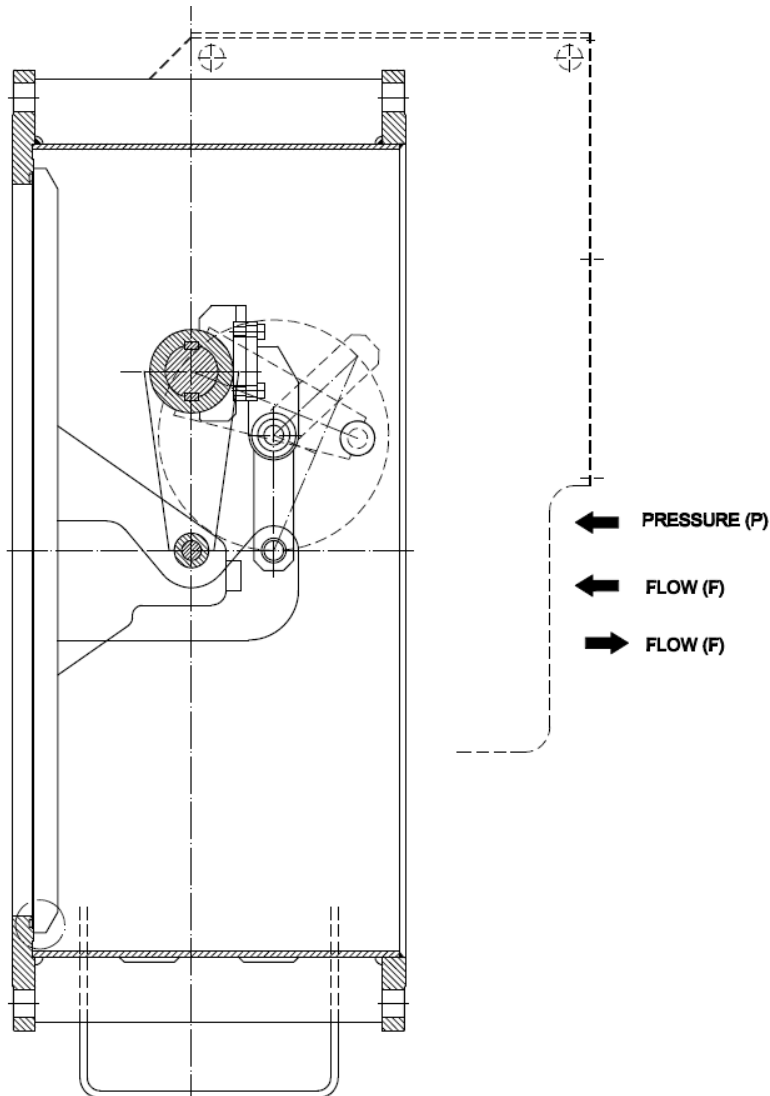

Special consideration should be given to keeping the correct distance between connection flanges and to ensuring that they are perfectly aligned and parallel.

The incorrect positioning of counter-flanges will cause strain on the valve body which could lead to operating problems.

The valve can be mounted in any position: horizontal, vertical or slanting, depending on the requirements of the installation. The operating shaft **MUST** be mounted in a horizontal position. In horizontal or slanting lines try to ensure that the shaft remains, not only horizontal, but also in the upper area.

If the valve has electrical accessories such as electric-actuator, solenoid valves, limit switches, electropneumatic positioners, etc. the corresponding earthing connections must be made before putting it in to operation.

In order to check its operation and tightness, operate the valve with no load and then with load. It is worth remembering that during transit / storage of the valve, the packing might have settled thus causing a small leak. Once there is pressure inside the valve this leak could be checked by applying soapy water to the packing gland area. This can be remedied by gently tightening the packing gland until the aforementioned leak is eliminated.

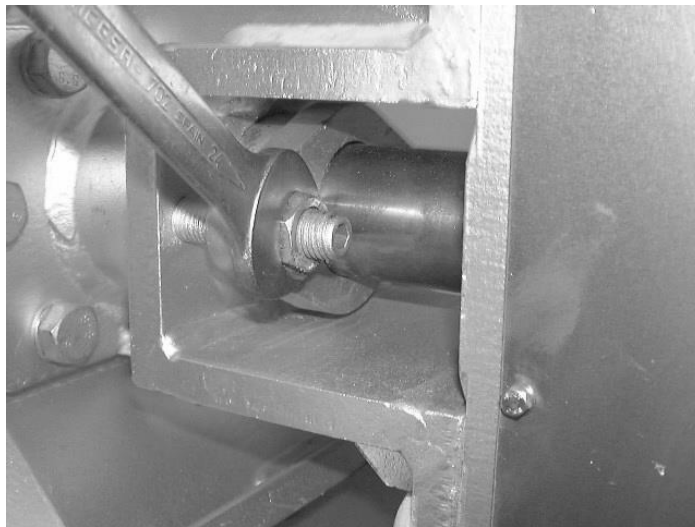

4. PNEUMATIC CYLINDER

A pneumatic double-acting linear cylinder which operates an adjustable lever fastened to the valve stem. These cylinders are designed for working at a minimum instrument air pressure of 3,5 bar to 4 bar. In tight valves, these cylinders are sized to open the valve at a differential pressure equivalent to 0.1 bar and 0.3 bar in metal-metal valves. They are not intended for operating the valve when it is submitted to line operating pressure (for example 6 bar).

It is recommended to have a replacement cylinder of each diameter or at least to have sets of replacement cylinder seals. Please refer to the pneumatic cylinder supplier's maintenance manual for changing the aforementioned seals.

5. MAINTENANCE



It is important to observe the following warnings to avoid personal injuries or damage to property when handling and installing the valve:

- Qualified and trained personnel must carry out the handling and maintenance of the valve.



- Use suitable Individual Protection Equipment (IPE) (gloves, safety footwear...).
- Disconnect all lines affecting the valve and put up a notice notifying that work is being carried out on the valve.
- Isolate the valve Completely from the process.
- Release process pressure.
- Drain the fluid from the valve.

The MI valves do not require any maintenance other than the replacement of the packing and seals in the tight valves.

The service life of these watertight elements depends on the valve's operating conditions such as pressure, temperature, abrasion and the number of operations.

5.1. Replacement packing kit

The packing kit includes 2 lines of synthetic packing made of 98% pure carbon filaments (MG-420), at the head and bottom which are wrapped around pre-formed pure mineral graphite rings (grafoil).

The circuit has to be depressurised before beginning any type of maintenance work.

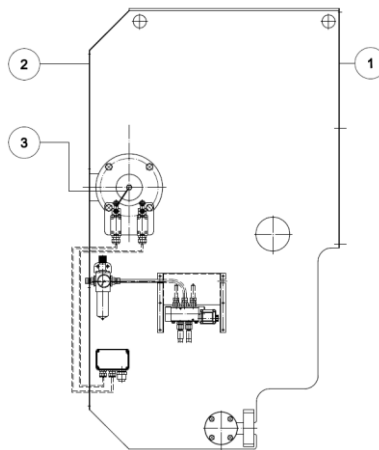

1. Loosen the indication for the detectors or limit switches (3).
2. Loosen the guards on the support plate (2) and (3).
3. Take out the stud bolt (54) fastening the main lever (27) to the valve stem (7). If the nut has a welding point remove it in order to be able to remove the stud bolt easily.

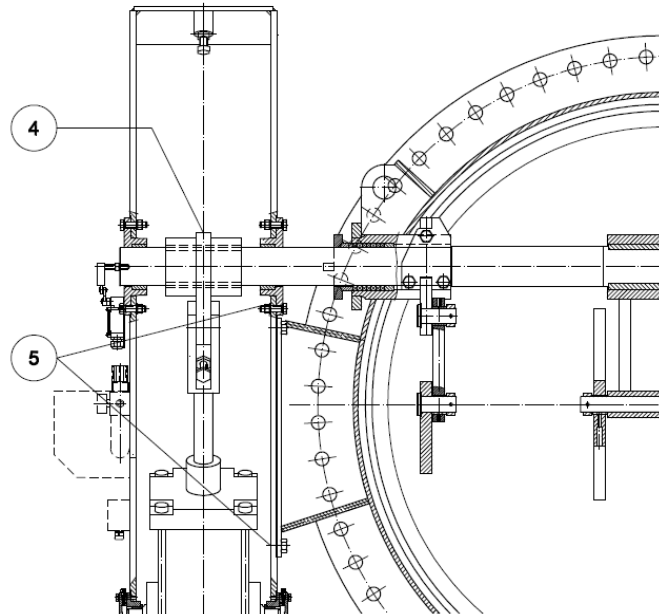

4. Loosen the lever locking nut (4) and bolts and nuts (5) joining the main support plate to the valve body.
5. Due to its weight use a crane to remove the whole assembly, composed of the support plate, cylinder and main lever.

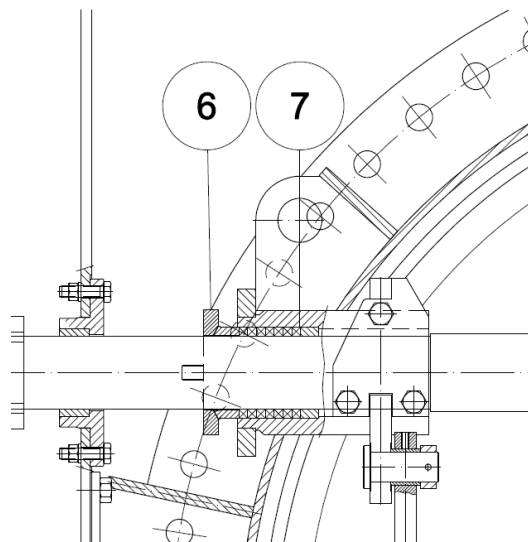

6. Remove the packing gland (6) completely and take out the packing (7) using a screwdriver and / or a packing extractor (ensure that nothing is left behind inside the groove).

7. Position the new packing fitting the bottom line (MG-420) and all the grafoil rings without fitting the head line. Position the packing gland (6) and tighten the above mentioned assembly with a torque of 20 N·m.
8. Remove the packing gland (6) and fit the head line (MG-420). Put the packing gland back (6) and tighten until the whole assembly is tightened.
9. Position the assembly composed of the support plate, cylinder and main lever. Proceed in reverse order from the disassembly for the assembly of the aforementioned assembly.
10. Carry out some operations with a loaded circuit and retighten the packing gland (6), only enough to prevent leaks. This check can be carried out using soapy water.

5.2. Replacement of the seal (only for tight valves)

The seal with reference HECKER AK-2749 is composed of aramid fibres impregnated with rubber on both sides and covered with a special material called centellen. This whole assembly is completed with a graphite coating. This seal is supplied as a closed ring.

1. Remove the valve from the pipe.
2. Open the valve and hold the disc open ensuring that it doesn't close.
3. Remove the old seal using a screwdriver and thoroughly clean the groove where the new seal is to be positioned. This groove has a dovetail-like design.
4. Position the new seal in the groove whilst supporting it over its entire perimeter



5. Carry out several operations since the disc, when moving, will end up homogeneously tightening the seal in its housing.

5.3. Replacement of the cylinder

The replacement of the cylinder in an MI valve can be carried out when the circuit is in operation. The time available for carrying out the replacement has to be kept in mind for proceeding before the next operation.

1. Shut off the air instruments valve to the pneumatic circuit.

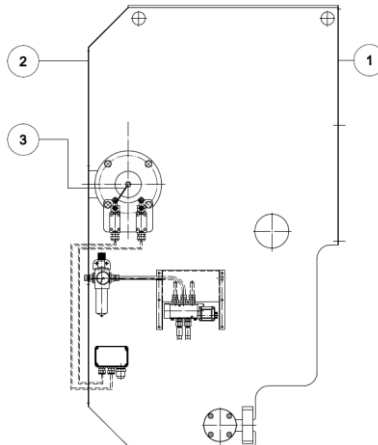

2. Loosen the support plate (2) and (3) guards.

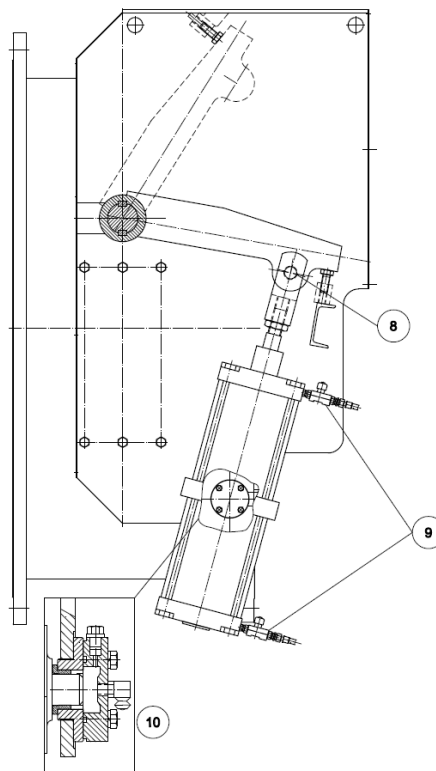

3. Remove the cylinder fork pin (8).
4. Dismount the pneumatic cylinder flow regulators (9).
5. Disassemble grease cover (10).
6. Move the cylinder fork towards the main valve stem and remove the cylinder from its housing.
7. Once the cylinder is dismounted remove its fork in order to position it in the new cylinder. When mounting the fork in the cylinder ensure that its machined part is kept towards the inside and not the outside.
8. For the assembly of the new cylinder work in reverse order from the disassembly.

5.4. Replacement of accessories

These valves are supplied with an air filter and pressure regulator. This pressure regulator is generally set to 4 bar.

Likewise, they include one-way flow regulators with a pneumatic pipe made of high-pressure flexible armoured rubber.

The supply includes double coil solenoid valves as well as proximity switches. It is recommended having spare parts for all these elements. Refer to the manufacturer's manual for maintenance advice regarding these items.

No specific instructions are required for replacing the accessories. Generally speaking, the air instruments valve to the pneumatic circuit is shut off before being able to change the accessories.

5.5. Greasing

These valves are supplied with greasing boxes in the intermediate cylinder connection.

Grease these points every 6 months using calcic grease with the following characteristics: insoluble in water, low ash content and excellent adhesion.

It is recommended including greasing boxes in valves which do not have any of these greasing systems.

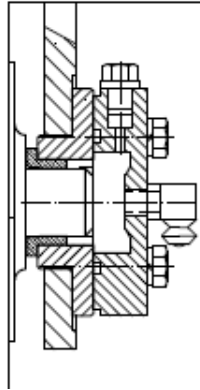

6. STORAGE

With the exception of the small sizes, these valves are individually packed.

After unloading, the valves have to be stored in a well-aired location under shelter to protect them from dust, dirt and dampness.

If storage outside is unavoidable, keep the valve away from heat, direct sunlight or protect from the effects of rain by using a coating. Keep well-aired to avoid dampness.

7. ENVIRONMENTAL CONSIDERATIONS

- The packaging is made from environmentally friendly materials. Dispose of the packaging through the available recycling channels
- The valve is designed and manufactured with materials that can be recycled by specialised recycling firms. Once the life of the product is expired, you have to consider a proper disposal of the product in order to prevent any negative impact on the environment and allows for the recycling of valuable commodities
- Please follow the local environmental rules in your country for proper disposal