

MODEL**CR****SERIES 70**

ROUND BY SQUARE PORT KNIFE GATE VALVE

The CR(SER.70) model knife gate is a wafer valve designed for the use in difficult applications. This valve is generally suitable for recycling applications, such as junk or sand traps of pulpers, high density cleaners (HDC) or as silo outlet with solid material. The two piece body with round inlet and square outlet (larger than the inlet) ensures non-jamming.

Sizes:

DN 4"/100mm to DN 24"/600mm (larger diameters on request)

Working pressure:

DN 4"/100mm to DN 16"/400mm: 100psi/(7 kg/cm²)

DN 20"/500mm to DN 24"/600mm: 60psi/(4 kg/cm²)

Standard flange connection:

EN 1092 PN 10 and ASME B16.5 (class 150)
(on valve round inlet only)

Others: on request

Option: For the square outlet, ORBINOX can also design a square-to-round transition piece

Directives:

For EU Directives and other Certificates, please see the document: Directives and Certificates Compliance - Knife Gate Valves - Catalogues and Datasheets



All valves are tested prior to shipping in accordance with the standard developed by the Quality Control Department at ORBINOX

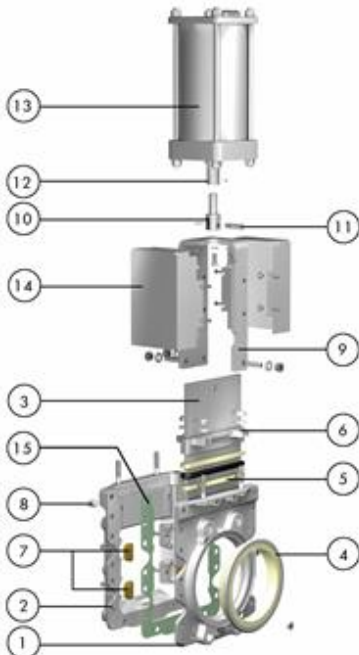

STANDARD PARTS LIST

Part:	Cast Iron:	Stainless Steel:
1- Body	GJL 250 (0.6025)	CF8M (1.4408)
2- Body	GJL 250 (0.6025)	CF8M (1.4408)
3- Gate	2205 (1.4462)	
4- Sleeve	Polyurethane Rubber	
5- Packing	Dynapack (Graphite impregnated PTFE and Aramid yarn combination with an elastomeric core)	
6- Gland Follower	CF8M	
7- Sliders	Bronze	
8- Cap	Galv. Steel	AISI 316 (1.4404)
9- Yoke	Carbon steel	AISI 304 (1.4301)
10- Clevis	17-4 PH	
11- Pin	AISI 304 (1.4301)	
12- Piston Rod	AISI 304 (1.4301)	
13- Cylinder	Aluminum	
14- Gate guards	AISI 304 (1.4301)	
15- Gasket	Aramid fibres	



Reserves the right to change specifications without notice

ORBINOX CANADA, ORBINOX USA, ORBINOX BRAZIL, ORBINOX CHILE, ORBINOX PERU, ORBINOX SPAIN, ORBINOX UK, ORBINOX FRANCE, ORBINOX GERMANY, ORBINOX INDIA, ORBINOX CHINA, ORBINOX S.E.A.

www.orbinox.com

OBX 03/22

Rev.7

CR (SER.70)_1

DESIGN FEATURES

BODY:

Cast two-part bolted body, internally machined and with reinforcing ribs in larger diameters for extra body strength. The internal replaceable gate guides allow for smoother gate traveling. The square outlet (reinforced with sliders) prevents the build-up of contaminants such as staples, wires, etc.

For the most severe applications, the body includes standard flush ports to flush out the solids that may interfere with the gate traveling.

GATE:

Duplex stainless steel gate, oversized thickness and polished on both sides, increases its wearing resistance and prevents damage to the seat.

This design also allows to perfectly cut through the fluid.

SEAT/POLYURETHANE SLEEVE:

The seat is composed of a highly resistant, long-lasting sleeve, made of polyurethane and with a stainless steel core.

This design allows for easy sleeve replacement and avoids gasket installation between the flange and the valve.

STEM:

The standard stainless steel stem offers a long corrosion resistant life. For those pneumatic actuated valves, stem linkage is provided by means of a stainless steel coupling and a pin (Fig. 1).

PACKING:

Long-life packing with several graphite impregnated PTFE and Aramid yarn combination with an elastomeric core, together with an easy adjusting and access packing gland ensuring a tight seal. Long-life braided packing is available in a wide range of materials.

YOKE OR ACTUATOR SUPPORT:

Compact design makes it extremely robust even under the most severe conditions. Reinforced design is standard starting from DN 10"/250mm.

EPOXY COATING:

The epoxy coating on all ORBINOX cast iron and carbon steel valve bodies and components is electrostatically applied making the valves to be corrosion resistant with a high quality finished surface. The ORBINOX standard colour is RAL-5015 blue.

GATE SAFETY PROTECTION:

ORBINOX automated valves are provided with gate guards in accordance with EU Safety Standards. The design feature prevents any objects from being caught accidentally while the gate is moving. *ONLY IN EUROPE



Fig.1

OTHER OPTIONS

Other materials of construction:

Special stainless steels and alloys such as AISI 317, 254SMO, Hastelloys, etc.

Fabricated valves:

ORBINOX designs, produces and delivers special fabricated valves for special process conditions (big sizes and/or high pressures)

PACKING ARRANGEMENT

Valve can be assembled with double packing or bonnet for a better performance of the valve

Double Packing

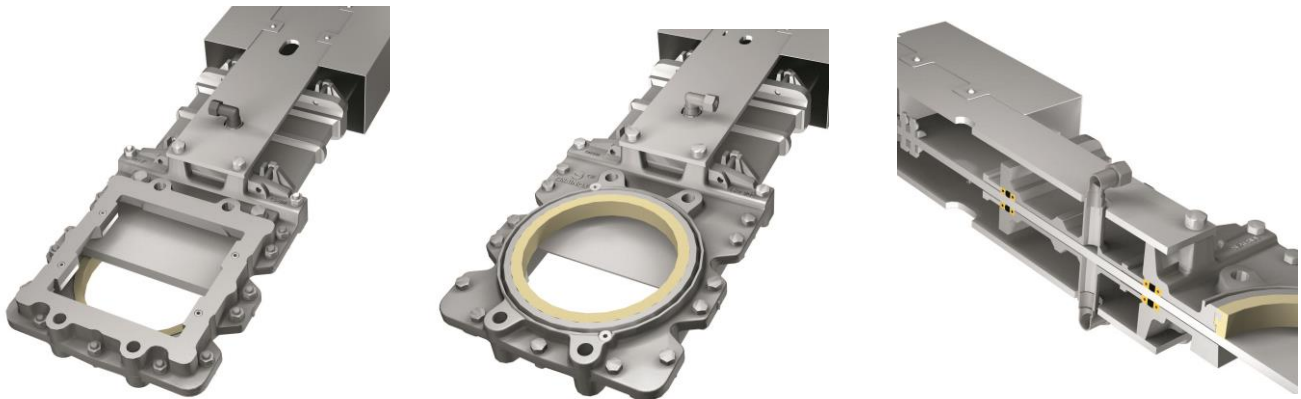

Bonnet

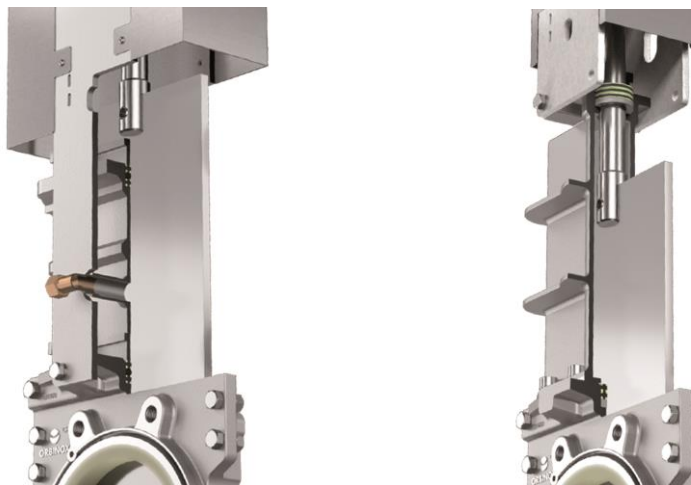

We recommend to contact our technical department

MODEL**CR****SERIES 70**

TEMPERATURE CHART

SEAT / SLEEVES

Material	T. max. (°F)	(°C)	Applications
Polyurethane	194	90	General

All of them are reinforced with a stainless steel core. More details and other materials on request

PACKING

Material	Max.T. (°F)	(°C)	pH
Dynapack (DP)	518	270	2-14
PTFE impregn. synth. fibre (ST)	482	250	2-13
Braided PTFE (TH)	500	260	0-14

SEAT TYPE

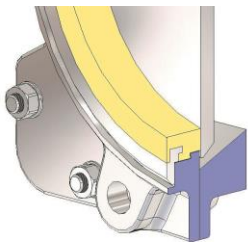

POLYURETHANE

The sealing of the CR(SER.70) valve is achieved through a high resistance elastomer sleeve, which improves the watertightness at both the flange and closing area. The sleeve has a stainless steel core with very good resistance to pressure and working conditions.

DOUBLE ACTING PNEUMATIC CYLINDER

- The standard pneumatic actuator (double acting on-off cylinder) consists of:

- $\varnothing \leq 12''/300\text{mm}$: Aluminum barrels
- $\varnothing \geq 14''/350\text{mm}$: Composite barrels
- Aluminium covers
- Stainless Steel (AISI 304) piston rod
- Nitrile coated steel piston

- Available from DN 4''/100mm to DN 24''/600mm

- Actuator sized for 85psi (6 kg/cm²) air supply

- Reinforced design of support plates (U type) is standard starting from DN 10''/250mm

- Options (on request):

- Hard anodized barrel and covers
- Stainless Steel barrel and covers
- Over/Undersized cylinder
- Manual override
- Fail safe system
- Limit switches

- Instrumentation (on request):

- Positioners
- Solenoid valves
- Flow regulators
- Air preparation units

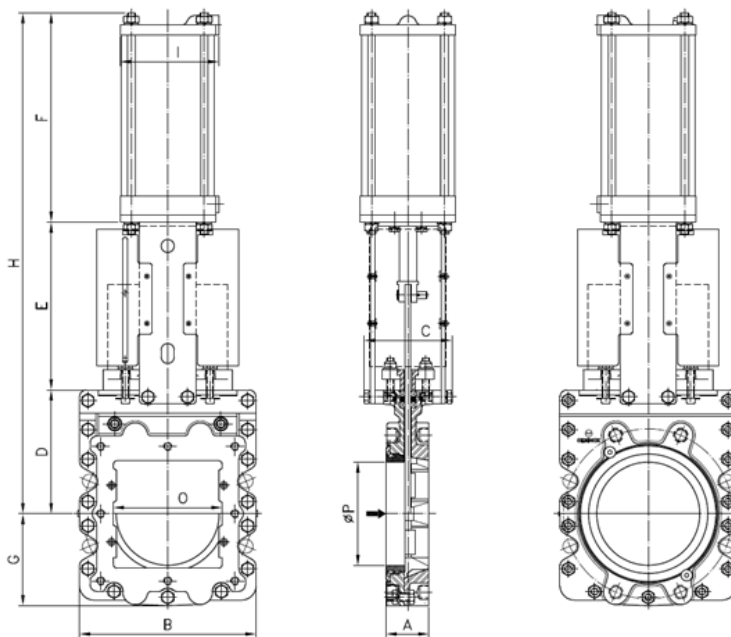

DN	A	B	C	D	E	F	G	H	I	O	P	Weight (lbs./kg.)	Std.Cyl.	Connect.
4"/100	2.03/52	8.11/206	4/100	5.51/140	7.80/198	8.86/225	4.33/110	22.16/563	4.52/115	3.74/95	3.81/97	77/35	C4"-4.52"/(100/115)	1/4"G
6"/150	2.36/60	9.92/252	4.25/108	6.89/175	9.33/237	11.65/296	5.11/130	27.87/708	5.51/140	5.71/145	5.75/146	172/78	C5"-6.30"/(125/168)	1/4"G
8"/200	2.36/60	12.40/315	4.84/123	8.07/205	12.16/309	14.09/358	6.61/168	34.33/872	6.89/175	7.63/194	7.63/194	196/89	C6.30"-8.66"/(160/220)	3/8"G
10"/250	2.72/69	15.28/388	7.28/185	9.84/250	14.80/376	16.85/428	7.63/194	41.49/1054	8.66/220	9.64/245	9.72/247	220/100	C8"-10.62"/(200/270)	3/8"G
12"/300	3.07/78	16.85/428	7.28/185	11.42/290	16.77/426	18.81/478	9.13/232	47.00/1194	8.66/220	11.57/294	11.73/298	320/145	C8"-12.60"/(200/320)	3/8"G
16"/400	3.50/89	22.04/560	10.63/270	15.43/392	22.60/574	23.58/599	11.49/292	61.61/1565	10.90/277	15.66/398	15.67/398	591/268	C10"-16.73"/(250/425)	3/8"G
20"/500	4.49/114	25.47/647	10.63/270	17.71/450	26.57/675	27.95/730	13.34/339	72.24/1835	13.18/335	19.64/499	18.85/479	816/370	C12"-20.67"/(300/525)	1/2"G
24"/600	4.49/114	29.41/747	10.63/270	20.08/510	30.51/775	31.89/830	15.63/397	82.48/2095	13.18/335	24/600	22.75/578	1118/507	C12"-24.60"/(300/625)	1/2"G

MODEL

CR

SERIES 70



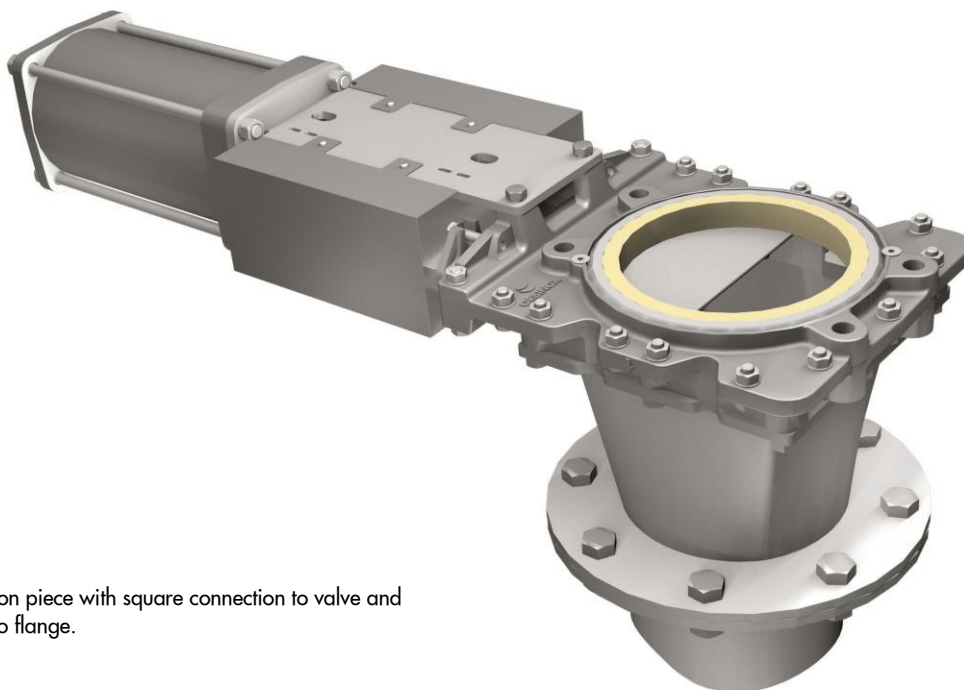
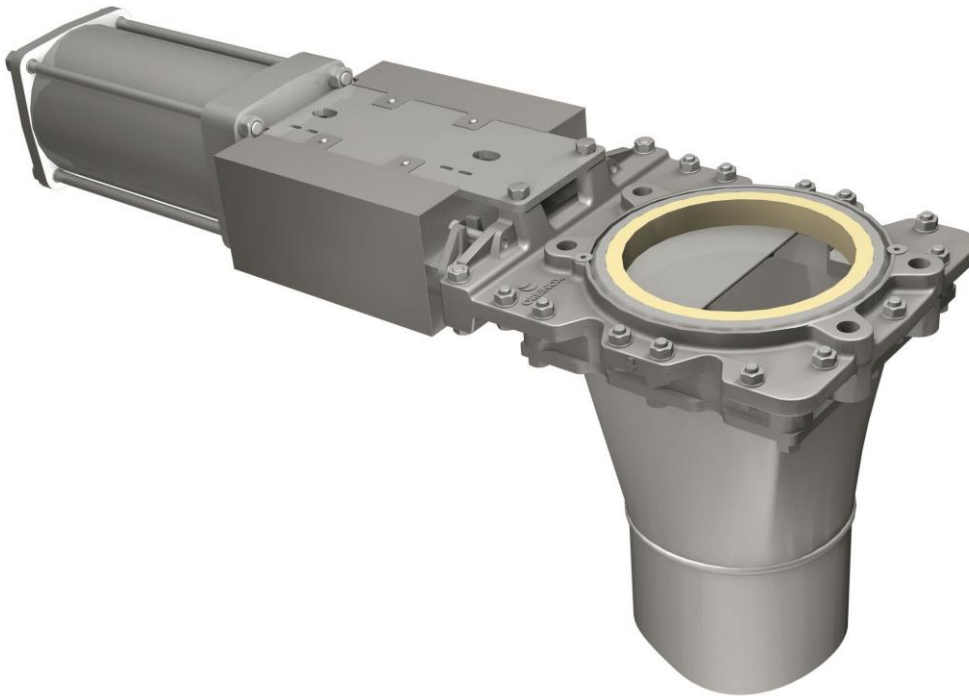

TRANSITION TYPES

The CR(SER.70) valve can be supplied with a square to round transition piece, that connects the valve square outlet with the round flange or pipe.





Transition piece with square connection to valve and round to flange.

MODEL**CR****SERIES 70****FLANGE DRILLING ROUND INLET SIDE****ASME B16.5, class 150**

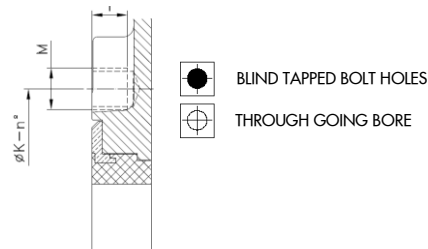
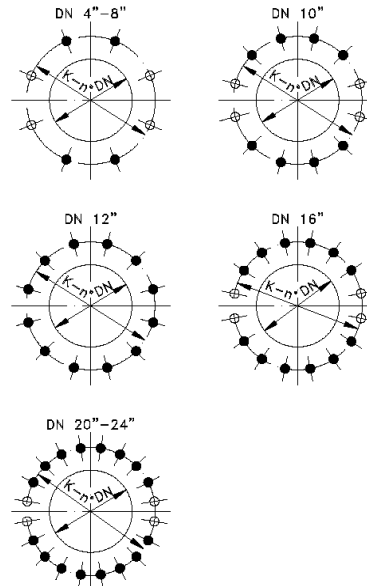
DN	K	n°	M	T	 
4"	7 1/2"	8	5/8" - 11 UNC	7/16"	4 - 4
6"	9 1/2"	8	3/4" - 10 UNC	5/8"	4 - 4
8"	11 3/4"	8	3/4" - 10 UNC	5/8"	4 - 4
10"	14 1/4"	12	7/8" - 9 UNC	5/8"	8 - 4
12"	17"	12	7/8" - 9 UNC	5/8"	12 - 0
16"	21 1/4"	16	1" - 8 UNC	7/8"	12 - 4
20"	25"	20	1 1/8" - 7 UNC	7/8"	16 - 4
24"	29 1/2"	20	1 1/4" - 7 UNC	7/8"	16 - 4

**EN 1092 PN10**

DN	K	n°	M	T	 
100	180	8	M-16	11	4 - 4
150	240	8	M-20	13	4 - 4
200	295	8	M-20	16	4 - 4
250	350	12	M-20	16	8 - 4
300	400	12	M-20	16	12 - 0
400	515	16	M-24	22	12 - 4
500	620	20	M-24	22	16 - 4
600	725	20	M-27	22	16 - 4

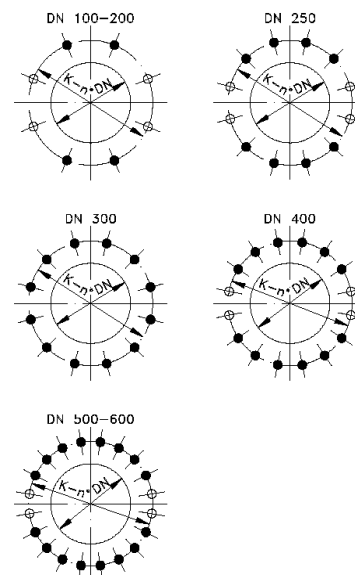

MODEL**CR****SERIES 70**
FLANGE DRILLING SQUARE OUTLET SIDE

DN ("/mm)	n°	K' (mm)	M'	T' (mm)
4"/100	8	70	M12	11
6"/150	8	95	M12	13
8"/200	8	122,5	M12	16
10"/250	8	150	M12	16
12"/300	12	124	M12	16
16"/400	12	154	M16	22
20"/500	12	187	M16	22
24"/600	16	170	M16	22

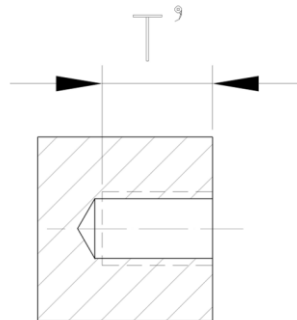
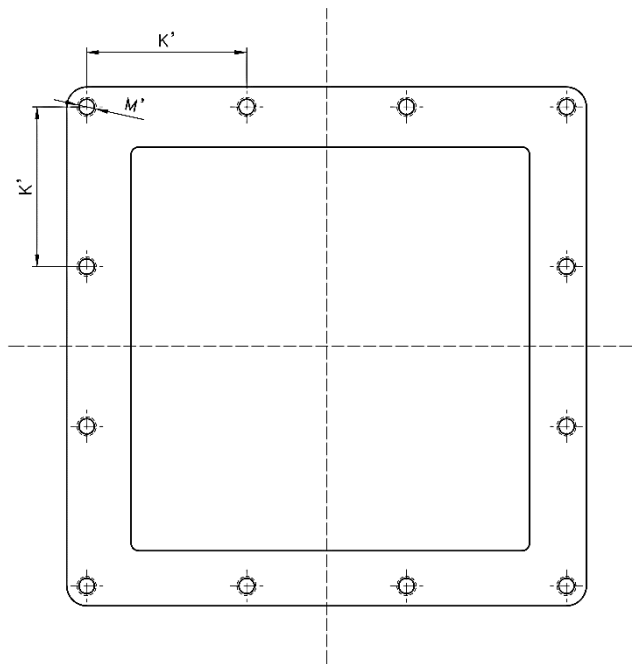

Contact ORBINOX for other flange drilling